

Series / Parallel / Split Switching with Two DPDT - e.g. Push-Pull Pots (possibly useful with Warman Humbucker and Vanson HBP90 combination – split to Screw)

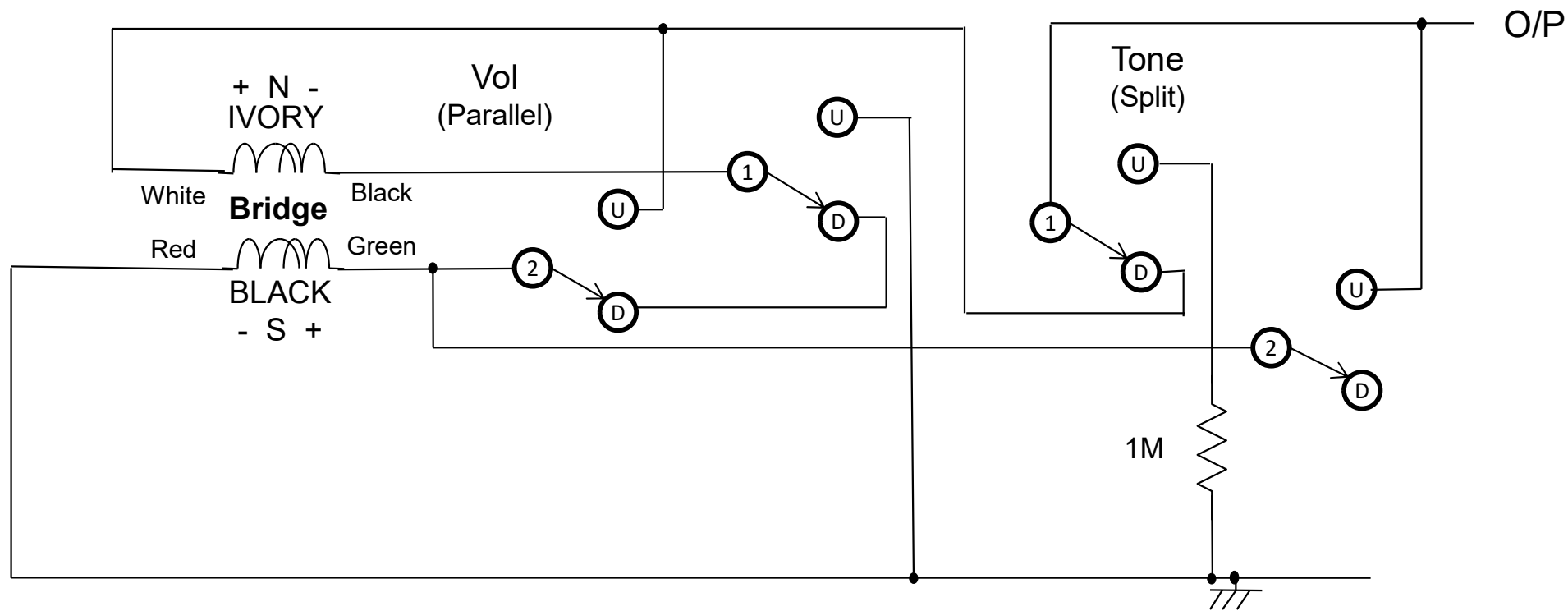

Vol	Tone	Configuration
Down	Down	Series Humbucker
Up	Down	Parallel
Down	Up	Split + 1M resistor across pot
Up	Up	Parallel + 1M resistor across pot

Tone and Volume Stages – Fender Grease Bucket and Treble Bleed

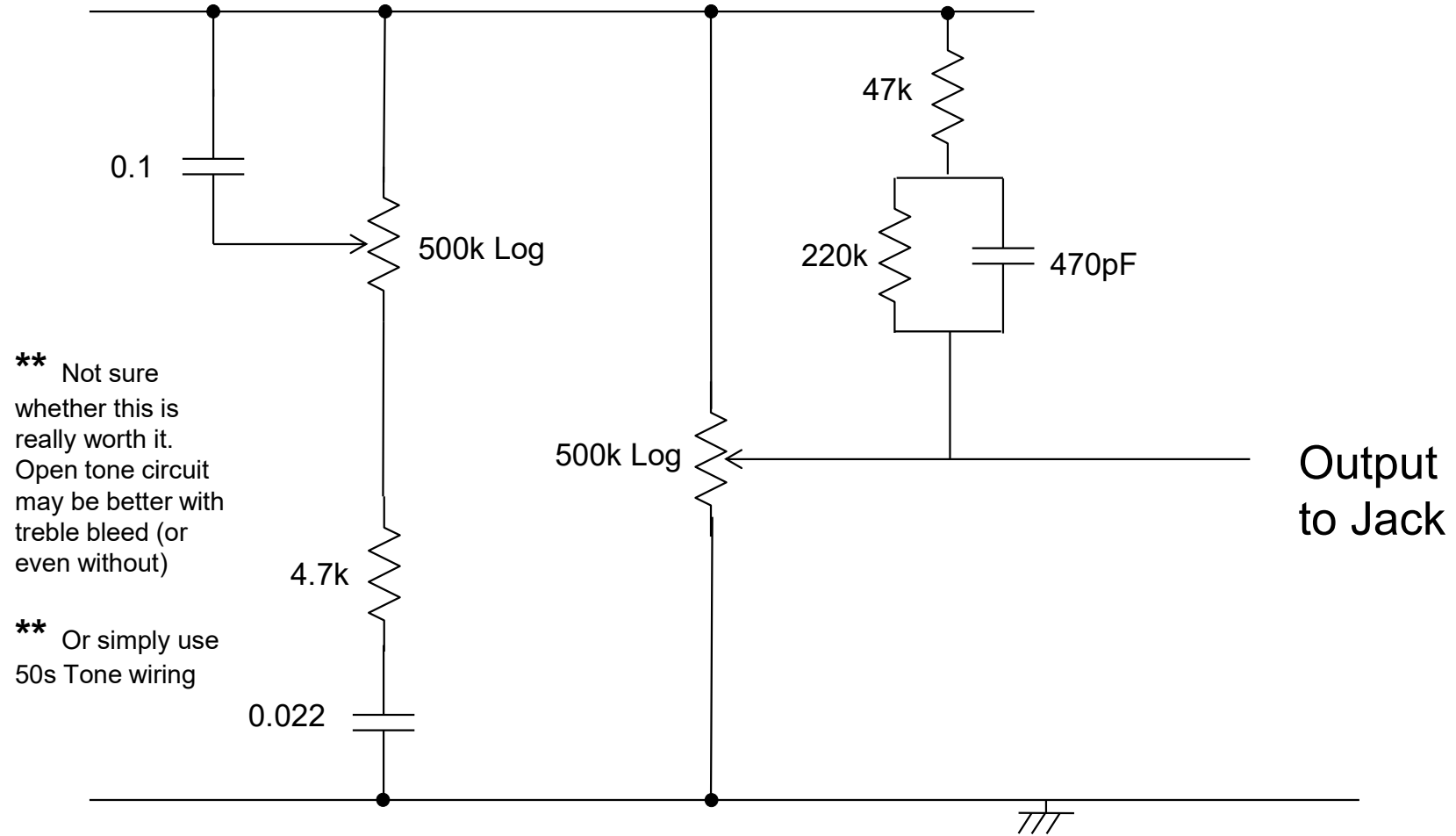

Tone and Volume Stages – 50s Wiring

